

RULES FOR RETAIL SALES OF CONSUMER FIREWORKS

The State Fire Marshal's Office enforces the 2003 edition of NFPA 1124, *Code for the Manufacture, Transportation, Storage, and Retail Sales of Fireworks and Pyrotechnic Articles*. The code contains a chapter detailing the sale of consumer (Class C) fireworks. The highlights of the requirements are listed in this document.

Fireworks Buildings

- Applies to new and existing buildings, structures and facilities (7.1.1)
 - Permanent stores
 - Tents
 - Stands
- Does not apply when the quantity of pyrotechnic composition does not exceed 125 pounds, or 25% of the gross weight of all fireworks, including packaging. (7.1.3.1)
- Consumer fireworks sales are permitted only in mercantile occupancies as defined in the Life Safety Code. (Not permitted in Business, Assembly, Storage, etc. occupancies) (7.1.5)
- Tents shall be flame-retardant per NFPA 102. (7.4.1 (a))
- When fireworks sales are conducted in multitenant buildings, all other tenants shall be separated from the fireworks sales by 2-hour fire rated construction. (1 hour fire rating if 100% sprinkler protected) (7.4.3.1)
- Storage rooms for fireworks in new, permanent sales facilities shall be fire sprinkler protected, or one-hour fire rated. (7.4.4)
- Permanent fireworks sales buildings over 6,000 square feet in area shall be protected throughout by a fire sprinkler system. (7.5.1.1)
- Portable fire extinguishers shall be provided. (7.5.2.1)
 - Two fire extinguishers are required for retail facilities greater than 200 sq. ft.
 - One extinguisher shall be a pressurized water type having a minimum rating of 2A.
 - The other must be a dry chemical multi-purpose extinguisher having a minimum rating of 4A.
 - Maximum distance to an extinguisher in a permanent building is 75 feet, 35 feet in a temporary stand.
- A smoke control system shall be provided in new permanent fireworks sales buildings when the ceiling is less than 10 feet in height and the travel distance to an exit exceeds 25 feet. (7.5.4.1)
- Fire Department apparatus access shall be provided to within 150 feet of any portion of the exterior of a fireworks sales facility. (7.6.1)
- The area around a fireworks sales facility shall be kept clear of dry grass, brush and combustible debris for a distance of at least 30 feet. (7.6.2)
- A vehicle or trailer used for fireworks storage shall be parked at least 10 feet from a fireworks sales facility. (7.6.3)
- Signage having 4-inch high letters stating
NO FIREWORKS DISCHARGE WITHIN 300 FEET
shall be posted outside the fireworks sales facility. (7.6.4)
- Smoking is prohibited within 50 feet of a fireworks sales area. Signage stating
FIREWORKS –NO SMOKING
in 2-inch high letters shall be provided at each entrance or aisle of a fireworks sales facility. (7.6.5)

- Separation Distances (7.7)

New permanent fireworks sales buildings shall comply with Table 7.7.1.1

Table 7.7.1.1 Separation Distances Between New Permanent Buildings and Structures

Separation Distances		Exterior Wall Fire Resistance Rating (hr)	Exterior Wall Opening Fire Protection Rating (hr)
m	ft		
< 3.05	< 10	2	1½
≥ 3.05 to < 18.3	≥ 10 to < 60	1	¾
≥ 18.3	≥ 60	0	0

- Existing fireworks sales buildings shall be separated from adjacent permanent buildings by 10 feet, or one-hour fire rated construction.
- A distance of at least 50 feet shall be maintained from:
 - Motor vehicle fuel dispensers
 - Retail propane dispensers
 - Aboveground tanks for flammable or combustible liquids, flammable gases, or flammable liquefied gases (propane)
- Temporary sales facilities (stands) shall meet the separation distances of Table 7.7.2

Table 7.7.2 Temporary Consumer Fireworks Retail Sales Facilities — Minimum Separation Distances

	Buildings		Combustibles ^a		Tents ^b		Vehicle Parking		Stands ^c		Storage of Consumer Fireworks	
	m	ft	m	ft	m	ft	m	ft	m	ft	m	ft
Tents^b	6.1	20	6.1	20	6.1	20	3.05	10	6.1	20	6.1	20
Stands^c	6.1	20	3.05	10	6.1	20	3.05	10	1.5 ^d	5 ^d	6.1	20

^a The required clearances to combustibles shall also comply with 7.6.2.

^b *Tents* refers to temporary consumer fireworks retail sales in tents, canopies, and membrane structures.

^c *Stands* refers to temporary consumer fireworks retail sales stands.

^d Where stands are separated from each other by less than 6.1 m (20 ft), the aggregate area of such stands shall not exceed 74 m² (800 ft²).

- A distance of at least 300 feet shall be maintained from:
 - Bulk flammable or combustible liquid, flammable gas or flammable liquefied gas (propane) tanks or dispensers
- All fireworks sales facilities (except temporary stands) shall have a fire safety and evacuation plan posted in a public location. The plan shall be approved by the Authority Having Jurisdiction. (7.8.2)
- Fireworks sales tents or sales buildings shall have at least 3 approved exits, except the Class C Mercantile occupancies (less than 3,000 sq. feet) and temporary stands shall have not less than 2 approved exits.
- Travel distance to an exit shall not exceed: (7.8.4)
 - 75 feet in tents and permanent fireworks sales facilities.
 - 35 feet in stands.
- Aisles used by the public shall have an unobstructed width of at least 48 inches. (7.8.5)
- Aisles not used by the public shall have an unobstructed width of at least 28 inches.
- Dead end aisles are prohibited (7.8.5.3.4)

- Where egress doors are provided for the public, they shall be side-hinged and swing in the direction of egress travel, shall be at least 36 inches in width and shall have panic hardware provided. (7.8.6)
- Egress openings in tents shall be at least 44 inches in width.
- Doors in temporary stands not used by the public do not require panic hardware and shall be at least 28 inches in width.
- Illuminated exit signs and emergency lighting shall be provided unless the fireworks sales facility is not open after dusk or in temporary stands not occupied by the public. (7.9)

Retail Sales Displays (7.10)

- Shelving and merchandise along exterior walls shall be no higher than 12 feet above the floor, 6 feet for interior placed items and 8 feet for stands not occupied by the public. (7.10.2)
- Flame Breaks (7.10.3)
 - As shown below, flame breaks shall be provided for shelving or displays of unpackaged fireworks exceeding 16 feet in length.
- Not required when fire sprinkler protected.
- Not required when a 44 inch aisle, or 8 feet of packaged fireworks or open space is provided. The total length without flame breaks cannot exceed 32 feet.
- Where display fixtures are back-to-back, a flame break shall be provided the length of the display.
- Freestanding display racks, pallets, tables or bins containing packaged fireworks do not require flame breaks when the display dimensions do not exceed 4 feet in width, 8 feet in length and 6 feet in height and is separated from other displays by 4 feet.
- Shelving used for fireworks display can have openings of not more than 10% of the area of the entire shelf, unless a flame break is provided, the fireworks are suspended or fixed to the shelving or packaged materials are used.
- Flame breaks are not required in stands not occupied by the public.

FIGURE A.7.10.3.4 Packaged Fireworks Merchandise and Flame Break Requirements.

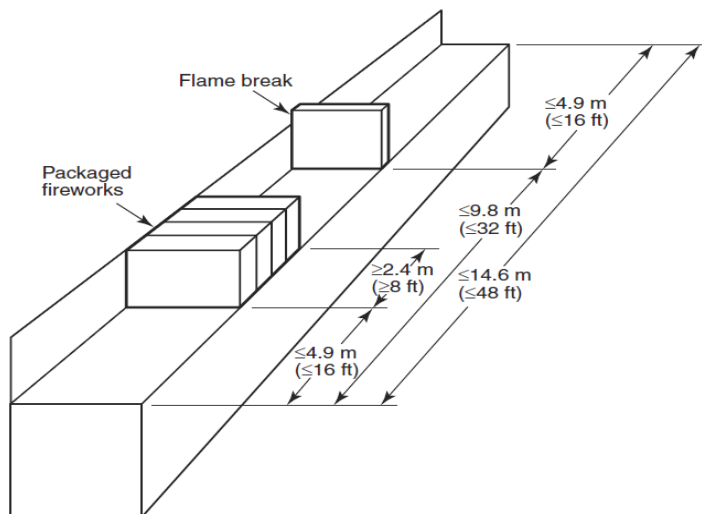

FIGURE A.7.10.3.4 Packaged Fireworks Merchandise and Flame Break Requirements.

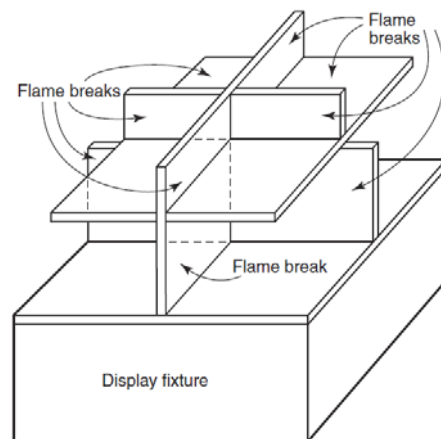

FIGURE A.7.10.3 Flame Break Design.

- All fireworks shall have covered fuses so that the fuse cannot be touched by a person without unwrapping, tearing or puncturing the package. This does not apply to stands not occupied by the public. (7.10.4)
- Fireworks sold in stores (mercantile occupancies) are permitted when:
 - The fireworks are under visual supervision by a store employee
 - The fireworks are packaged and are displayed in a manner that will limit the travel if accidental ignition occurs.
 - Combustible materials and other merchandise shall not be stored directly above fireworks unless a horizontal barrier is provided. (7.10.5)
- Electrical wiring and equipment shall meet NFPA 70. This includes physical protection of temporary wiring from pedestrian or vehicle traffic (7.11)
- Portable generators shall be placed at least 20 feet from fireworks sales.
- Fuel for generators shall be limited to 5 gallons for diesel and 2 gallons for gasoline.
- Fuel storage shall be at least 20 feet from fireworks sales. (7.11.3)
- Cooking equipment of any type not permitted within 20 feet of tents or canopies used for fireworks sales.
- Open flame cooking equipment is not permitted within 50 feet of tents or canopies used for fireworks sales. (7.11.4)
- The means of egress (doors, aisles) shall be kept clear at all times. (7.12.1.1)
- Fireworks shall not be displayed within 5 feet of a public entrance or within 2 feet of a public exit or private entrance of an enclosed building. (7.12.2)
- At least 50% of available sales floor area of fireworks sales facilities shall be open space used for aisles and cross aisles.
- Fireworks sales displays shall not exceed 40% of the floor area used for sales in permanent fireworks sales buildings. (7.12.4)

Housekeeping

- Sales and storage areas shall be free of debris and rubbish.
- All loose pyrotechnic composition shall be removed immediately.
- Vacuums, shopvacs or other mechanical cleaning devices are not permitted.
- Brooms, dustpans and brushes shall be of non-sparking materials.
- Damaged fireworks devices shall be removed immediately and returned to the dealer, or destroyed. (7.12.5)
- All employees handling fireworks shall be safety trained. (7.12.6)
- Any person selling fireworks shall not knowingly sell to a person under the influence of drugs or alcohol (7.12.7)
- Fireworks inventory records shall be kept at the premises and shall be available to the Authority Having Jurisdiction upon request. (7.13)